

FD 210-22

CONTI® Double Convolution Air Spring

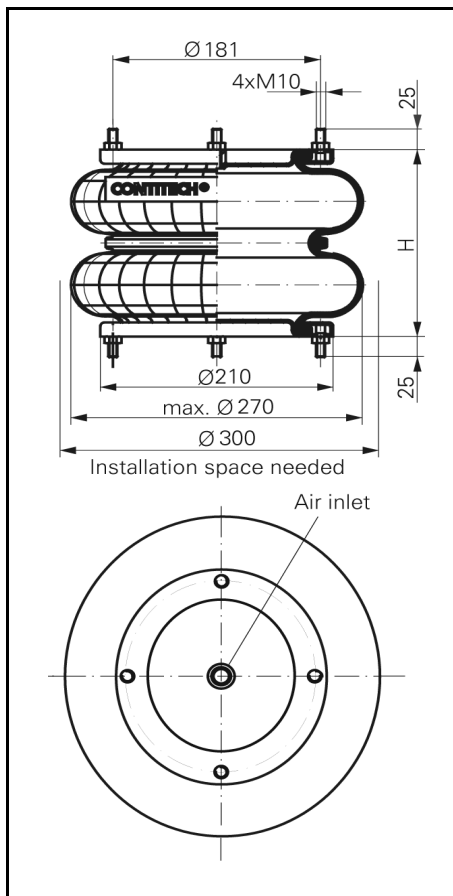

FD 210-22

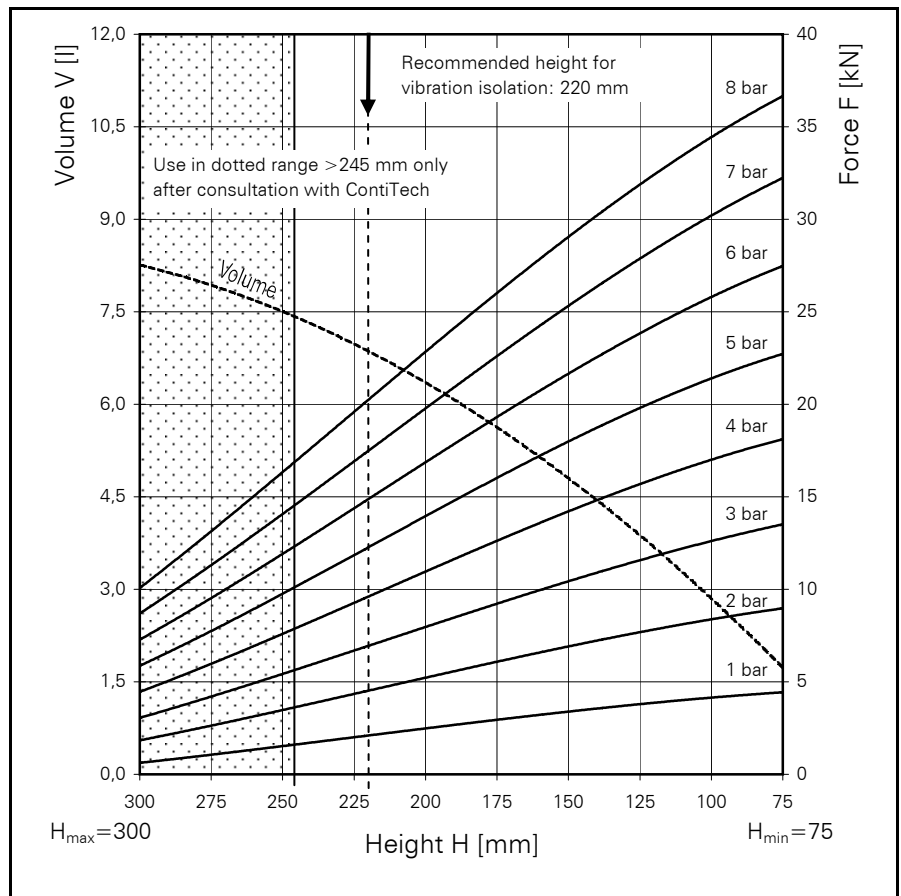

Force-height diagram

Purchase order data

Type	Order No.
Rubber bellows only	50478
With removable plates and G 1/2 air inlet	50473

Additional types on request

Technical data

Min. pressure	0 bar
Return force to min. height	≤ 250 N
Overall weight with metal plates	4.80 kg

Vibration isolation - dynamic characteristic values

Design height H: recommended 220mm, minimum 200mm

Pressure p [bar]	3	4	5	6	7	8	Vol V[l]
Force (Load) [kN]	7.0	9.45	11.95	14.45	16.88	19.38	
Spring rate [N/cm]	905	1140	1390	1620	1870	2110	
Natural frequency [Hz]	1.8	1.8	1.7	1.7	1.6	1.6	

Pneumatic application - static characteristic values

Force F [kN]

Pressure p [bar]	3	4	5	6	7	8	Vol.[l]	
Height H [mm]	250	5.6	7.8	10.0	12.2	14.4		7.6
	200	7.8	10.8	13.7	16.6	19.4		6.4
	150	10.4	14.2	18.0	21.7	25.4		4.7
	100	12.8	17.2	21.6	26.0	30.4	2.8	



Service instructions

M10 = 25 Nm

G 1/2 = 25 Nm