

**FS 138-8**

**CONTI® Single Convolution Air Spring**

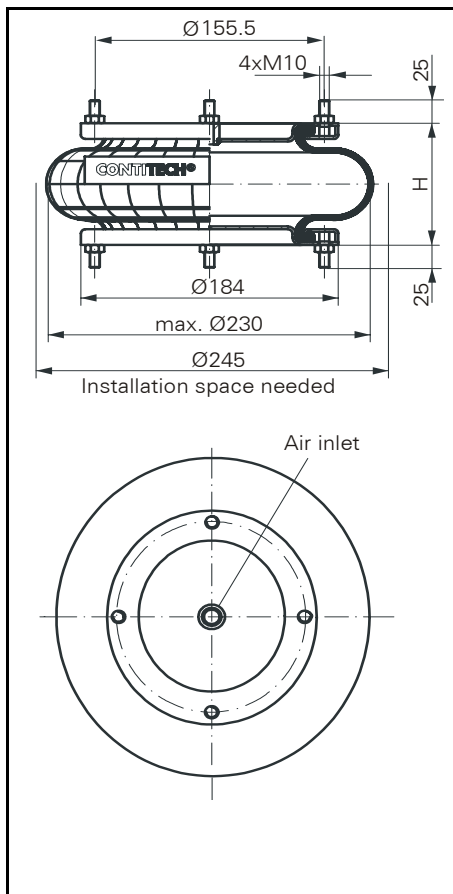

FS 138-8

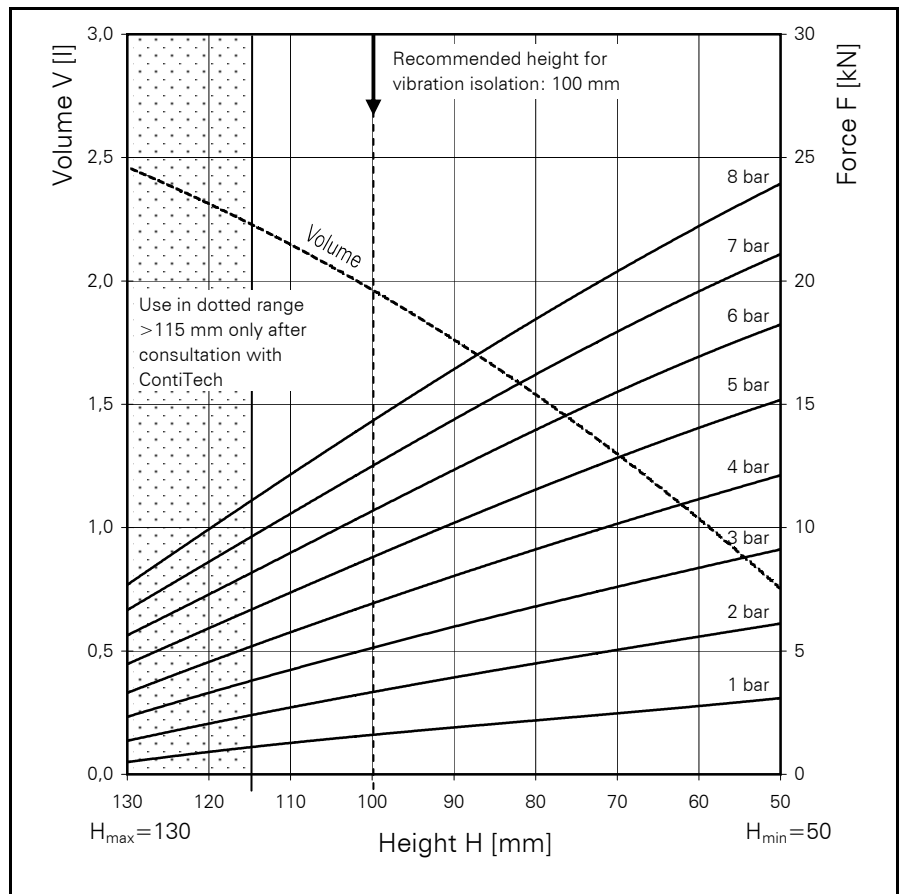

Force-height diagram

**Purchase order data**

Type	Order No.
Rubber bellows only	on request
With removable plates and G 1/2 air inlet	50608

Additional types on request

**Technical data**

Min. pressure	0 bar
Return force to min. height	≤ 130 N
Overall weight with metal plates	3.1 kg

**Vibration isolation - dynamic characteristic values**

Design height H: recommended 100mm, minimum 75mm

Pressure p [bar]	3	4	5	6	7	8	Vol. V [l]
Force (Load) [kN]	5.0	6.7	8.5	10.2	12.0	13.9	
Spring rate [N/cm]	1315	1705	2085	2480	2865	3250	
Natural frequency [Hz]	2.6	2.5	2.5	2.5	2.4	2.4	

**Pneumatic application - static characteristic values**

Force F [kN]

Pressure p [bar]	3	4	5	6	7	8	Vol.[l]	
Height H [mm]	120	3.4	4.6	6.0	7.3	8.7		10.0
	100	5.1	6.9	8.8	10.7	12.5		14.3
	80	6.8	9.1	11.5	13.9	16.2		18.4
	60	8.4	11.2	14.1	17.0	19.7		22.3



Service instructions  
 M10 = 25 Nm  
 G 1/2 = 25 Nm