

FS 1710-12

CONTI® Single Convolution Air Spring

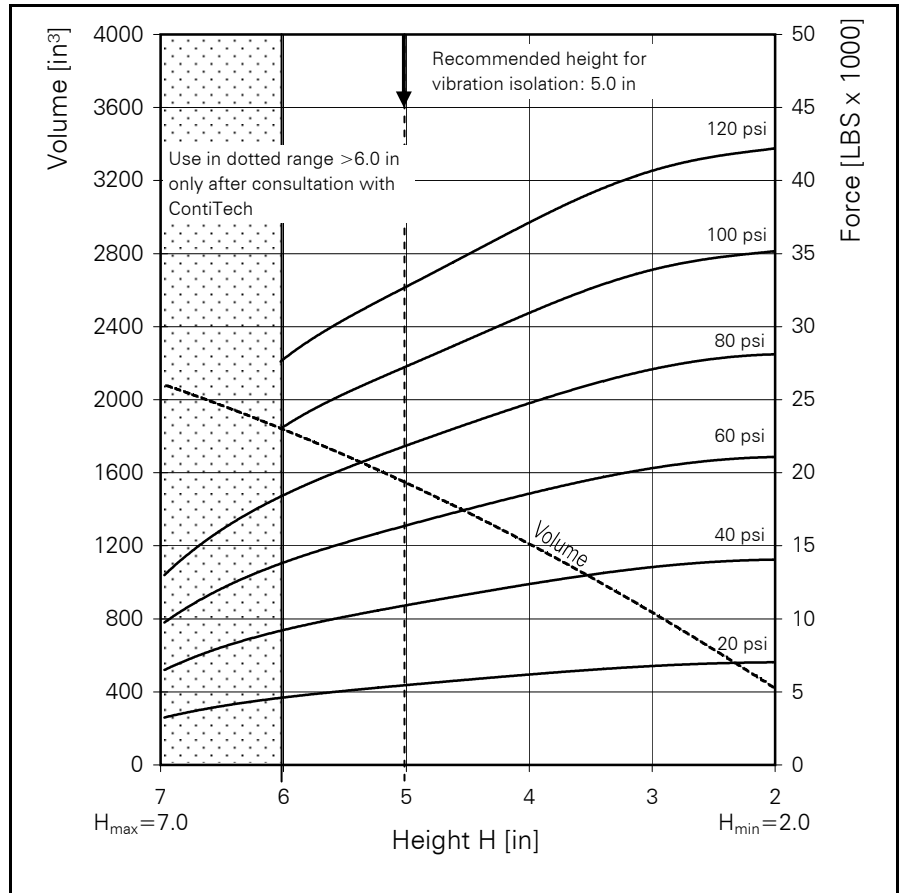
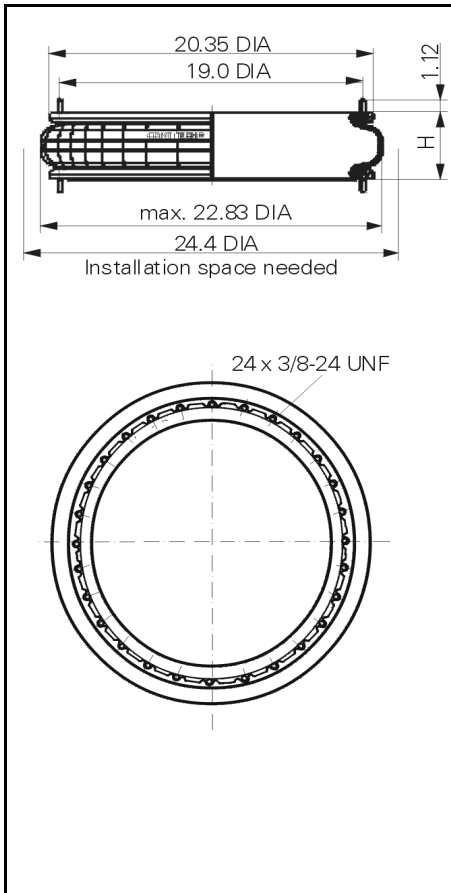

FS 1710-12

Force-height diagram

Purchase order data

Type	Order No.
Rubber bellows only	61782
Bellows with bead rings, 1 7/8 bolts, nuts and washers	on request

Additional types on request

Technical data

Min. pressure	0 psi
Return force to min. height	≤ 27 lbs
Overall weight with bead rings, bolts, nuts and washers	19.2 lbs

Vibration isolation - dynamic characteristic values

Design height H: recommended 5 inch, minimum 4.33 inch

Pressure p [psi]	40	60	80	100	120		Vol. V [in <sup>3</sup> ]
Force (Load) [lbs]	10900	16350	21800	27250	32700		1544
Spring rate [lbs/in]	5349	7606	9770	12114	14456		
Natural frequency [Hz]	2.2	2.2	2.1	2.1	2.1		

Pneumatic application - static characteristic values

Force F [lbs]

Pressure p [psi]	20	40	60	80	100	120	Vol [in <sup>3</sup> ]
Height H [in]	6.0	4620	9250	13870	18500	23120	1836
	5.0	5450	10900	16350	21800	27250	1544
	4.0	6190	12390	18580	24780	30970	1195
	3.0	6760	13510	20270	27020	33780	842



Service instructions

3/8-24 UNF = 28-32 LBxFT