

FS 330-11

CONTI® Single Convolution Air Spring

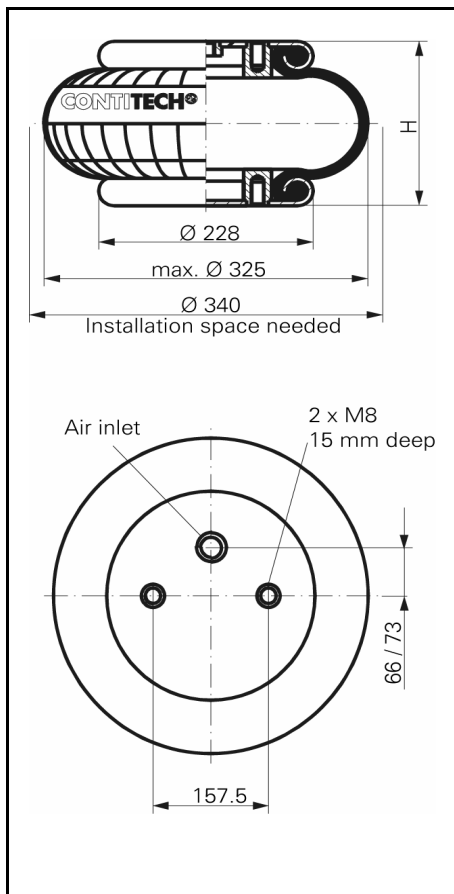

FS 330-11

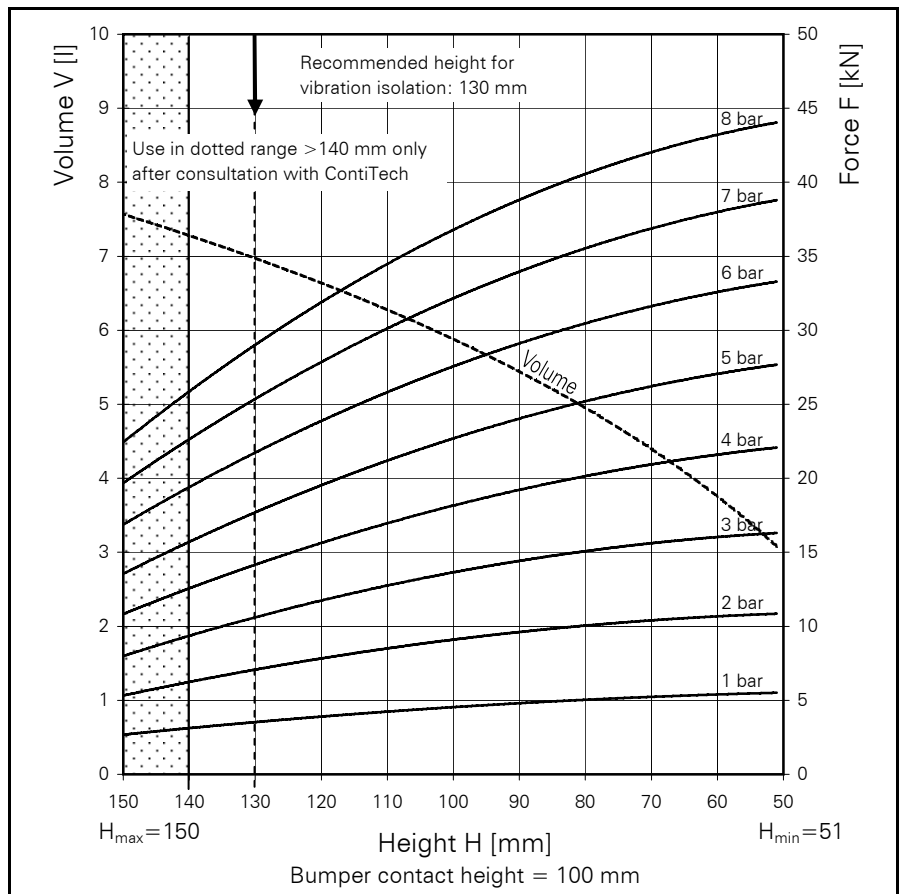

Force-height diagram

Purchase order data

Type	Order No.
Rubber bellows only	60314
With clamped plates G 1 air inlet 66 mm excentral	2681 060 000
With clamped plates G 1/4 air inlet 73 mm excentral	60424
With bumper G 1/4 air inlet 73 mm excentral	2681 062 000
With clamped plates G 3/4 air inlet 73 mm excentral	62743

Additional types on request



- Service instructions
- M8 = 25 Nm
- G 1 = 50 Nm
- G 1/4 = 25 Nm

Technical data

Min. pressure	0 bar
Return force to min. height	≤ 300 N
Overall weight with clamped plates	4.1 kg

Vibration isolation - dynamic characteristic values

Design height H: recommended 130mm, minimum 100mm

Pressure p [bar]	3	4	5	6	7	8	Vol. V [l]
Force (Load) [kN]	10.7	14.2	17.8	21.8	25.4	29.0	7.0
Spring rate [N/cm]	2645	3290	3935	4580	5225	5870	
Natural frequency [Hz]	2.5	2.4	2.4	2.3	2.3	2.3	

Pneumatic application - static characteristic values

Force F [kN]

Pressure p [bar]	3	4	5	6	7	8	Vol.[l]
Height H [mm]	130	120	110	100	90	80	70
	10.7	11.9	12.7	13.6	14.4	15.0	15.5
	14.2	15.7	16.9	18.1	19.2	20.2	20.9
	17.8	19.6	21.1	22.7	24.0	25.2	26.2
	21.8	23.8	25.8	27.6	29.1	30.5	31.6
	25.4	27.8	30.1	32.1	34.0	35.5	36.9
	29.0	31.8	34.4	36.7	38.9	40.6	42.1
	7.0	6.7	6.3	5.8	5.3	4.8	4.3
	6.0	5.5	5.1	4.7	4.3	3.9	3.8