

FS 44-5

CONTI® Single Convolution Air Spring

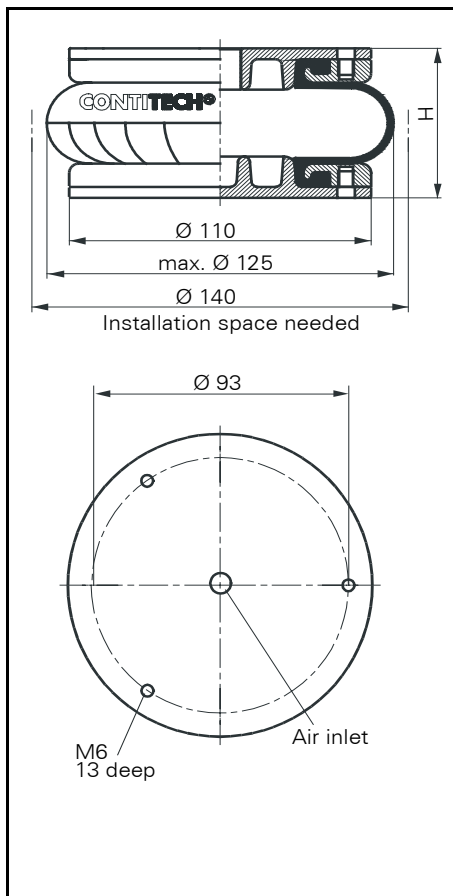

FS 44-5

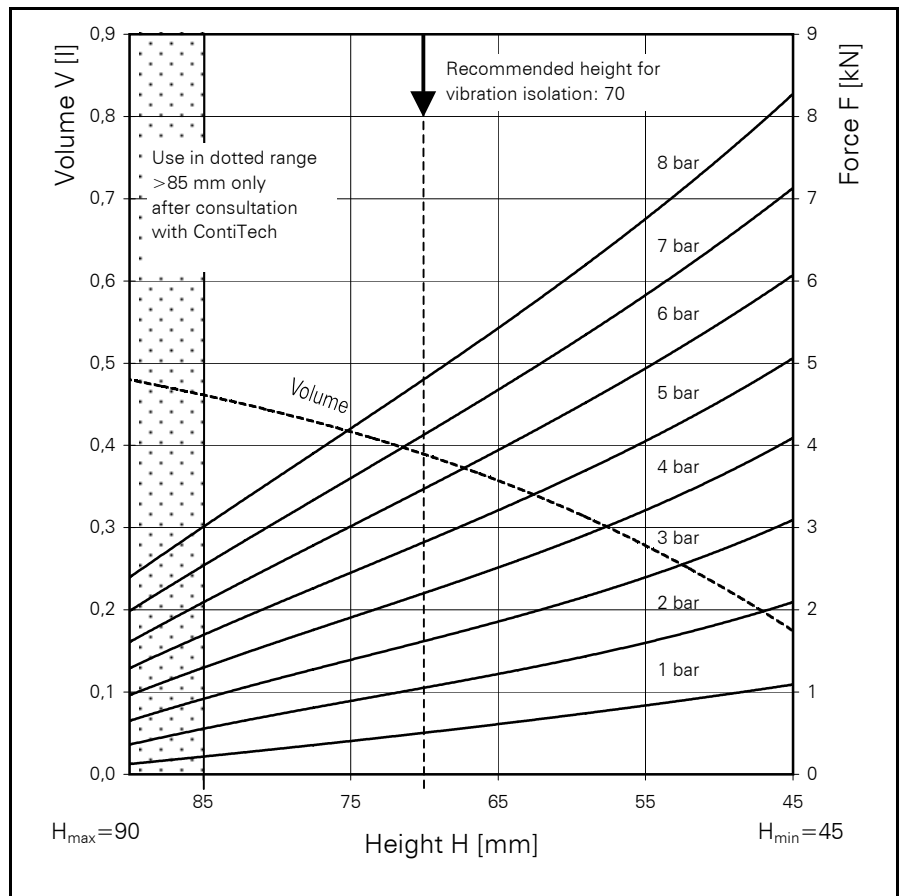

Force-height diagram

Purchase order data

Type	Order No.
Rubber bellows only	50698
With aluminium plates G 3/8 air inlet	50693

Additional types on request

Technical data

Min. pressure	0 bar
Return force to min. height	≤ 150 N
Overall weight with aluminium plates	0.8 kg

Vibration isolation - dynamic characteristic values

Design height H: recommended 70mm, minimum 65mm

Pressure p [bar]	3	4	5	6	7	8	Vol V[l]
Force (Load) [kN]	1.7	2.3	2.9	3.5	4.2	4.8	
Spring rate [N/cm]	960	1230	1510	1785	2050	2340	
Natural frequency [Hz]	3.8	3.6	3.6	3.5	3.5	3.5	

Pneumatic application - static characteristic values

Force F [kN]

Pressure p [bar]	3	4	5	6	7	8	Vol.[l]	
Height H [mm]	80	1.2	1.6	2.1	2.6	3.1		3.6
	70	1.6	2.2	2.8	3.5	4.1		4.8
	60	2.1	2.9	3.6	4.4	5.2		6.1
	50	2.7	3.6	4.6	5.5	6.5		7.5



Service instructions
M6 = 5 Nm
G 3/8 = 15 Nm